

AC Axial Fan 172x150x38mm(Ver.A)

■ 尺寸图 (DIMENSION DRAWING)

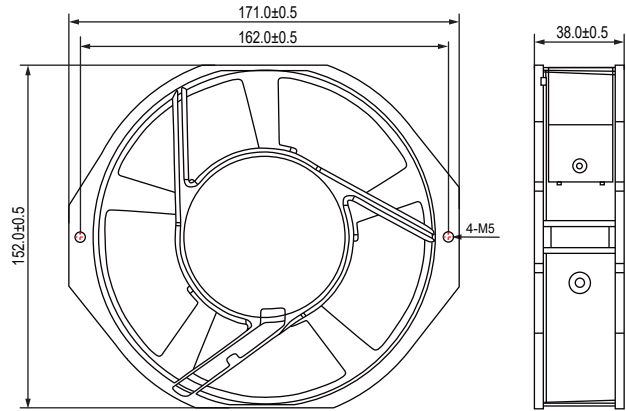

Unit:mm

- * 轴承类型:滚珠轴承 (Bearing type:2-ball)
- * 材料(Material):
框(Frame):铝合金Aluminum Alloy
扇叶(Impeller):PBT(UL94V-0)
- * 引线(Lead wire):
UL1015 AWG #22(Optional)
- * 马达(Motor):Capacitor-start induction motor
- * 保护(Protection): Impedance protection
- * 重量(Weight):760g

■ 风压&风量曲线图 P and Q CURVE

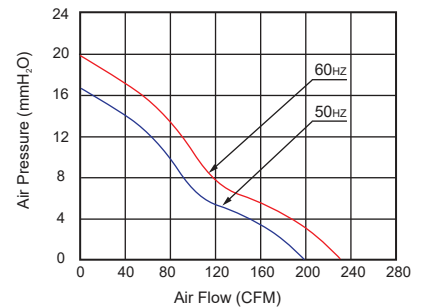

| 型号 Model | 轴承类型 Bearing Type | 电压 Voltage | 频率 Frequency | 电流 Current | 功率 Input Power | 转速 Speed | 风量 Air Flow | 风压 Static Pressure | 噪音 Noise Level |
|--------------|----------------------|---------------|-----------------|---------------|-------------------|-------------|----------------|-----------------------|-------------------|
| | | VAC | Hz | Amp | Watt | RPM | CFM | MM-H ₂ O | dBA |
| CC170B10L(T) | 2-Ball | 100-120 | 50/60 | 0.27/0.24 | 31/25 | 2,850/3,300 | 195/230 | 16.5/19.8 | 52/55 |
| CC170B20L(T) | 2-Ball | 220-240 | 50/60 | 0.14/0.11 | 31/25 | 2,850/3,300 | 195/230 | 16.5/19.8 | 52/55 |

- * 以上为额定电压下的常规参数(All readings are typical values at rated voltage)
- * 规格如有变动不另行通知(Specifications are subjected to change without prior notice)