

AC Axial Fan 280x280x80mm

■ 尺寸图 (DIMENSION DRAWING)

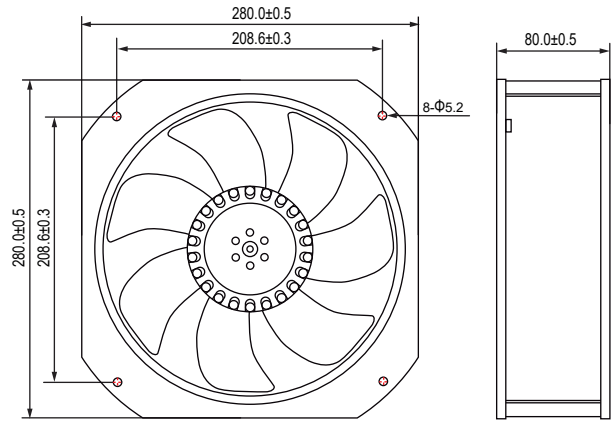

Unit:mm

- * 轴承类型:滚珠轴承 (Bearing type:2-ball)
- * 材料(Material):
框(Frame):铝合金Aluminum Alloy
扇叶(Impeller):铁Iron
- * 引线(Lead wire):
UL1015 AWG #22(Optional)
- * 马达(Motor):Capacitor-start induction motor
- * 保护(Protection): Impedance protection
- * 重量(Weight):2800g

■ 风压&风量曲线图 P and Q CURVE

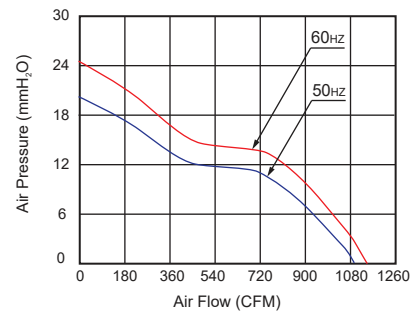

型号 Model	轴承类型 Bearing Type	电压 Voltage	频率 Frequency	电流 Current	功率 Input Power	转速 Speed	风量 Air Flow	风压 Static Pressure	噪音 Noise Level
		VAC	Hz	Amp	Watt	RPM	CFM	MM-H ₂ O	dBA
CC280H10L(T)	2-Ball	100-120	50/60	1.10/1.60	120/160	2,600/2,850	1090/1130	20.6/24.2	65/68
CC280H20L(T)	2-Ball	220-240	50/60	0.60/0.84	120/160	2,600/2,850	1090/1130	20.6/24.2	65/68

- * 以上为额定电压下的常规参数(All readings are typical values at rated voltage)
- * 规格如有变动不另行通知(Specifications are subjected to change without prior notice)