

AC Axial Fan 80x80x25mm

■ 尺寸图 (DIMENSION DRAWING)

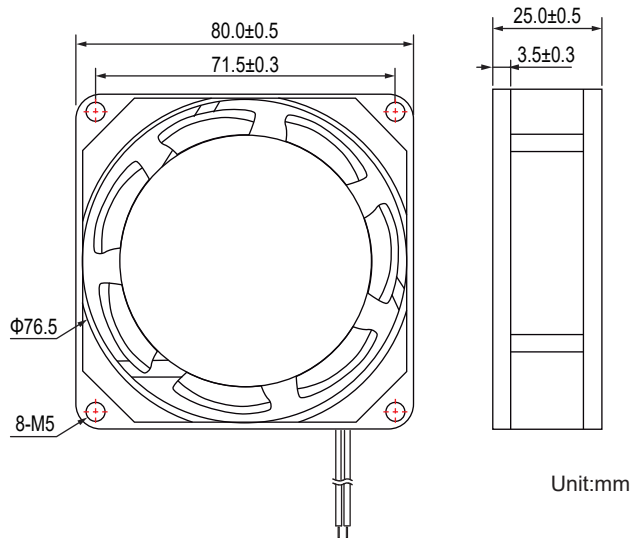

- * 轴承类型:滚珠轴承 (Bearing type:2-ball)
- * 材料(Material):
框(Frame):铝合金Aluminum Alloy
扇叶(Impeler):PBT(UL94V-0)
- * 引线(Lead wire):
UL1430 AWG #22(Optional)
- * 马达(Motor):罩极马达Shaded pole
- * 保护(Protection): Impedance protection
- * 重量(Weight):260g

■ 风压&风量曲线图 P and Q CURVE

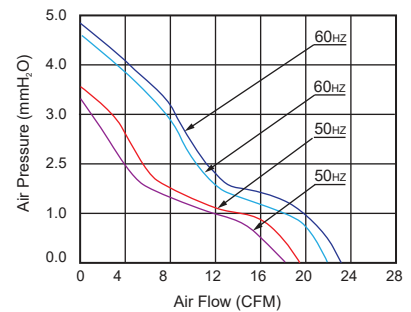

型号 Model	轴承类型 Bearing Type	电压	频率	电流	功率	转速	风量	风压	噪音
		VAC	Hz	Amp	Watt	RPM	CFM	MM-H ₂ O	dBA
CC80A10L(T)	2-Ball	100-120	50/60	0.12/0.10	14.0/13.5	2550/2900	18/22	3.3/4.6	29/33
CC80A20L(T)	2-Ball	220-240	50/60	0.07/0.06	14.0/13.5	2550/2900	18/22	3.3/4.6	29/33
CC80A10L(T)	2-Ball	100-120	50/60	0.18/0.14	14.0/11.0	2600/3100	19/23	3.5/4.8	30/35
CC80A20L(T)	2-Ball	220-240	50/60	0.09/0.07	14.0/11.0	2600/3100	19/23	3.5/4.8	30/35

- * 以上为额定电压下的常规参数(All readings are typical values at rated voltage)
- * 规格如有变动不另行通知(Specifications are subjected to change without prior notice)